

**NELSON  
HEAT TRACE**

---

# Installation & Maintenance

---

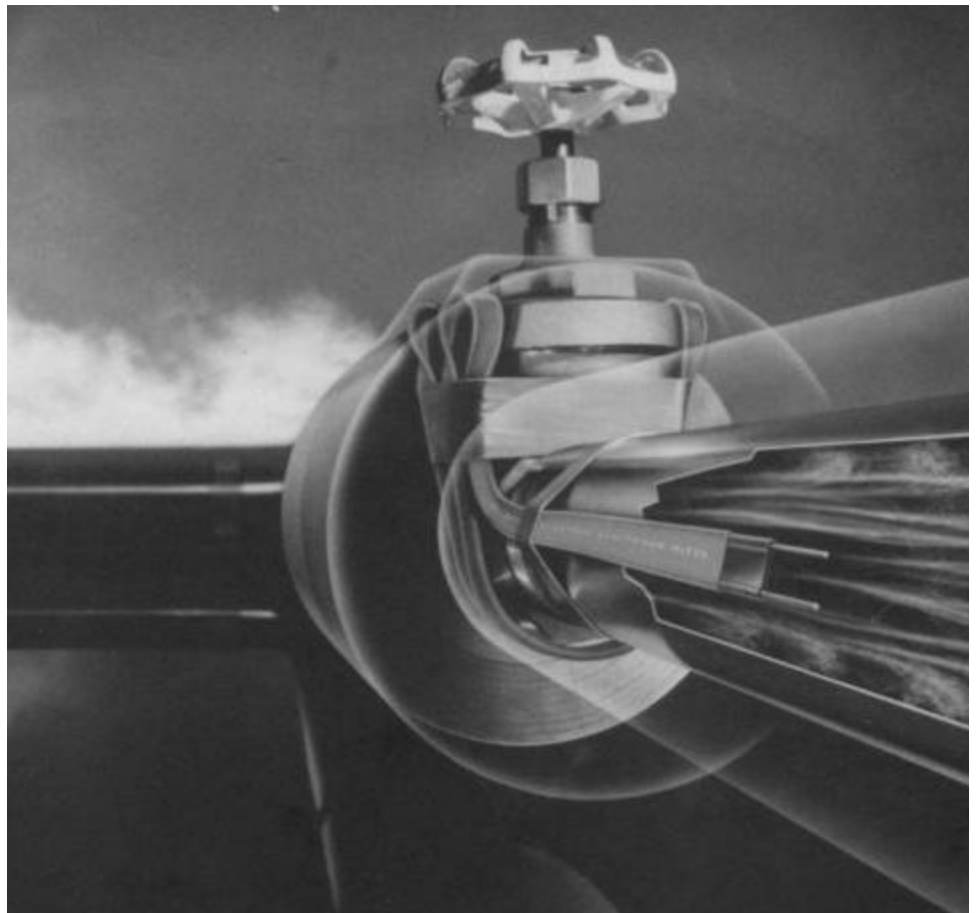

---

SELF-REGULATING  
**HEATER CABLE**

---

---

## CONTENTS

CONTENTS .....	2
GENERAL INFORMATION.....	4
<i>How Heating Systems Work</i> .....	4
PRODUCT SELECTION.....	4
RECEIPT & STORAGE.....	4
<i>Receipt</i> .....	4
<i>Storage</i> .....	4
<i>Withdrawal from Storage</i> .....	5
CONDITIONS OF SAFE USE.....	6
INSTALLATION .....	8
<i>Scheduling</i> .....	8
<i>Pre-Installation Check</i> .....	8
<i>Heater Handling</i> .....	8
<i>Heater Cable Location</i> .....	9
<i>Straight Tracing</i> .....	9
<i>Spiraling</i> .....	9
<i>Attachment</i> .....	10
<i>Cutting the Heater Cable</i> .....	10
<i>Installation Details</i> .....	10
SYSTEM COMPONENTS.....	13
<i>Accessories</i> .....	13
THERMAL INSULATION .....	14
<i>Pre-Installation Checks</i> .....	14
<i>Installation</i> .....	14
<i>Marking</i> .....	15
THERMOSTATS & SENSORS .....	15
ELECTRICAL REQUIREMENTS .....	15
<i>Voltage Rating</i> .....	15
<i>Electrical Loading</i> .....	15
<i>Protection Requirements for Branch Circuits</i> .....	15
<i>Waterproofing</i> .....	16
<i>Testing</i> .....	16
<i>Procedure</i> .....	17
START-UP .....	20
<i>Heat-up Time</i> .....	20
<i>Diversity Factor</i> .....	20
OPERATION & MAINTENANCE .....	20

---

<i>System Design, Installation &amp; Documentation</i> .....	20
<i>Preventive Maintenance</i> .....	20
<i>Visual Inspections</i> .....	20
<i>Frequency</i> .....	20
<i>Personnel Training</i> .....	20
<i>Maintenance</i> .....	21
<i>Piping Repairs</i> .....	21
DAMAGED PRODUCTS .....	21
TROUBLESHOOTING .....	22

---

## GENERAL INFORMATION

The Installation and Maintenance Manual is intended for use with Nelson Heat Trace self-regulating heating cable and component system on insulated pipes and vessels only. These instructions are suitable for use with the heating cables and components listed on sheets 5, 6 and 13. For applications not specifically addressed, please contact your local representative.

### ***How Heating Systems Work***

An electric heating cable system uses the heater cable to replace the heat that is lost through the thermal insulation system. Replacing the lost heat allows the pipe and product inside the pipe to be kept at a constant temperature. This will keep water from freezing and bursting a pipe, or a liquid from setting up and plugging the pipe. Simple systems may turn the entire system on with a contactor or switch, while others will use a thermostat or controller with each heater cable to regulate the temperature.

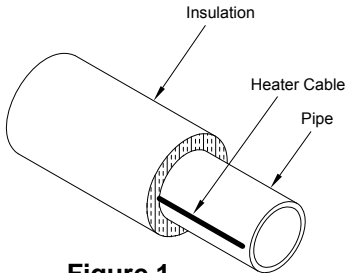

**Figure 1**

## PRODUCT SELECTION

Check and verify that the proper heater cables are being installed on each pipe and vessel. If no design/installation documents exist, check Nelson Heat Trace Design & Selection Guides to determine the proper equipment for the application.

## RECEIPT & STORAGE

### ***Receipt***

- Compare the material received against the shipping bill to verify receipt of the correct product and quantities.
- Inspect heating cable and components for any shipping damage. Insulation resistance tests on each spool of cable are recommended.
- If design documents (line lists or per circuit bills of material) exist, check the received material against the lists to verify all needed materials. If no design documents exist, keep a receipt log of all materials received.
- Record Lot Numbers on the Heat Trace Installation Record (see Figure 15) for product traceability. Lot number coding is printed on the heating core of HLT and QLT cables, and on the first electrical jacket of all other cables. The last 2 digits designate the year of manufacture and the preceding digits represent the sequential lot numbering format. Example: 35407 would represent lot number 354 manufactured in 2007. Lot numbers are repeated every 30.5cm (12.0"). Lot numbers can also be located on each shipping spool identification label.

### ***Storage***

Cable and system components should be stored in a clean, dry area. The equipment should be protected from mechanical damage during storage. The storage temperature range is  $-40^{\circ}\text{C}$  to  $+60^{\circ}\text{C}$  ( $-40^{\circ}\text{F}$  to  $+140^{\circ}\text{F}$ ).

---

### ***Withdrawal from Storage***

It is recommended that a check out record be kept (in conjunction with the receipt records) on equipment as it is removed from storage. This will serve to identify material shortages before they happen as project additions often cause the use of material for other than designated piping.

## CONDITIONS OF SAFE USE

### Ordinary Locations:

For ordinary location approvals, please refer to marking on respective product or contact manufacturer.

### Hazardous Locations:

**Compliance with Safety Requirements has been assured by compliance with:**  
 NEC® 2005; NFPA 70: National Electrical Code®, International Electrical Code Series  
 IEEE Std 515™-2004 Standard for the Testing, Design, Installation, and Maintenance of Electrical Resistance Heat Tracing for Industrial Applications  
 IEEE Std 515.1™-2005 Standard for the Testing, Design, Installation, and Maintenance of Electrical Resistance Heat Tracing for Commercial Applications

### UL

Certificate No.	Coding
LT: E49805	Class I, Division 2, Group ABCD. Class II, Division 2, Group FG. Class III, Division 2. Class I, Zone 1 and 2, Group IIC
QLT: E49805	Class I, Division 2, Group ABCD. Class II, Division 2, Group FG. Class III, Division 2. Class I, Zone 1 and 2, Group IIC
HLT: E49805	Class I, Division 2, Group ABCD. Class II, Division 2, Group FG. Class III, Division 2. Class I, Zone 1 and 2, Group IIC
D1-LT: E49805	Class I, Division 1, Group BCD. Class II, Division 1 Group EFG. Class III
D1-HLT: E49805	Class I, Division 1, Group BCD. Class II, Division 1 Group EFG. Class III

### FM

Certificate No.	Coding
LT: AM2A4.AF	Class I, Division 2, Group BCD. Class II and III, Division 2, Group G. Class I, Zone 1, Group IIC
HLT: AM2A4.AF	Class I, Division 2, Group BCD. Class II and III, Division 2, Group G. Class I, Zone 1, Group IIC
D1-LT: 3004655	Class I, Division 1, Group BCD Class I, Zone 1, Group IIB
D1-HLT: 3004655	Class I, Division 1, Group BCD. Class I, Zone 1, Group IIB





### CSA

Certificate No.	Coding
LT: LR 42104	Class I, Division 1 and 2, Group BCD. Class II, Division 1 and 2, Group EFG. Class I, Zone 1 and 2, Group IIB+H2. Zone 1, Ex e II T6 (T5)
HLT: LR 42104	Class I, Division 1 and 2, Group BCD. Class II, Division 1 and 2, Group EFG. Class I, Zone 1 and 2, Group IIB+H2. Zone 1, Ex e II T3

**Compliance with the Essential Health and Safety Requirements has been assured by compliance with:**

**ATEX:** EN 60079-0:2006, EN 60079-30-1:2007, EN 61241-0:2006, EN 61241-1:2004  
**IECEx:** IEC 60079-0:2004, IEC 60079-30-1:2007, IEC 61241-0:2004, IEC 61241-1:2004

**KEMA**

Certificate No.	Coding
LT: KEMA 07ATEX0124	0344  II 2 G Ex e II T6 (LT3, LT23, LT5, LT25) II 2 D Ex tD A21 T 80°C II 2 G Ex e II T5 (LT8, LT28, LT10, LT210) II 2 D Ex tD A21 T 95°C
QLT: KEMA 07ATEX0124	0344  II 2 G Ex e II T3 II 2 D Ex tD A21 T 195°C
HLT: KEMA 07ATEX0124	0344  II 2 G Ex e II T3 II 2 D Ex tD A21 T 195°C
LLT: KEMA 08ATEX0147U*	0344  II 2 G Ex e II T5 II 2 D Ex tD A21 T 95°C

**IECEx**

Certificate No.	Coding
LT: KEM 07.0041	Ex e II T6 (LT3, LT23, LT5, LT25) Ex tD A21 IP66 T 80°C Ex e II T5 (LT8, LT28, LT10, LT210) Ex tD A21 IP66 T 95°C
QLT: KEM 07.0041	Ex e II T3 Ex tD A21 IP66 T 195°C
HLT: KEM 07.0041	Ex e II T3 Ex tD A21 IP66 T 195°C
LLT: KEM 08.0033U*	Ex e II T5 Ex tD A21 T 95°C

\* Connections and terminations for installation with the LLT heating cable series shall be certified according to the requirements of the applicable standards for their types of protection for potential explosive gas and/or combustible dust atmosphere, as well as the requirements of IEC 60079-30-1 as integral parts of this trace heating system.

For more specific details on approvals, please refer to marking on respective product or contact manufacturer.

**Electrical Data:**

Product	Rated Voltage	Maximum Steady-State Current
LT, QLT, HLT	100V, 110V, 120V	18 Amps
LT2, QLT2, HLT2	200V, 208V, 220V, 230V, 240V, 277V	18 Amps
D1-LT, D1-HLT	100V, 110V, 120V	18 Amps
D1-LT2, D1-HLT2	200V, 208V, 220V, 230V, 240V, 277V	18 Amps
LLT	200V, 208V, 220V, 230V, 240V, 277V	38 Amps

**Specifications:**

	LT	QLT	HLT	D1-LT	D1-HLT	LLT
Maximum Maintain Temperature	65°C (150°F)	120°C (250°F)	120°C (250°F)	65°C (150°F)	120°C (250°F)	65°C (150°F)
Maximum Continuous Exposure Temperature (continuous power on)	65°C (150°F)	120°C (250°F)	120°C (250°F)	65°C (150°F)	120°C (250°F)	65°C (150°F)
Maximum Intermittent Exposure Temperature (1000 hours cumulative exposure)	85°C (185°F)	120°C (250°F)	190°C (375°F)	85°C (185°F)	190°C (375°F)	85°C (185°F)
Temperature Classification (Cable wattage if applicable)	T6 (3, 5) T5 (8, 10)	T3	T3	T6 (3, 5) T5 (8, 10)	T3 (3 - 15) T2C (18, 20)	T5
Minimum Installation Temperature	-40°C (-40°F)	-40°C (-40°F)	-40°C (-40°F)	-40°C (-40°F)	-40°C (-40°F)	-40°C (-40°F)
Minimum Bend Radius at -40°C (-40°F)	25.0 mm (1.0 in)	25.0 mm (1.0 in)	25.0 mm (1.0 in)	25.0 mm (1.0 in)	25.0 mm (1.0 in)	25.0 mm (1.0 in)

---

## INSTALLATION

### **General Information**

While there are many acceptable ways of installing Nelson Heat Trace electric heating equipment, certain actions can be dangerous to personnel and your installations. Please take care to avoid the following problems:

- **Do not twist the bus wires together at either end of the heater cable. Each of these wires has a voltage or neutral applied to it; twisting them together will cause a short circuit.**
- **Insulate the black polymer surrounding the bus wires. The black compound around the bus wires is electrically conductive and should be treated as a conductor.**
- **De-energize all power circuits before installation or servicing.**
- **To prevent electrical arcing and fire hazard, all cable connections and electrical wiring connections should be sealed against moisture. This includes the use of proper cable sealing kits and the moisture proofing of all wire connections.**
- **The metal sheath/braid of the heater cable must be connected to a suitable ground path.**
- **Do not use products containing plasticizers, such as vinyl electrical tape, or duct tape when installing self-regulating heater cables.**
- **Do not expose heater cables to temperatures above their maximum ratings. Higher temperatures can greatly shorten the life of a heater cable.**
- **Immediately replace any damaged heater cable or components. Failure to replace any damaged components (heater cable, components, or thermal insulation) will result in system failure.**
- **Classified areas (explosive dust or gases) require the use of special electrical components. Any area having explosive gases (such as chemical / petrochemical installations) or explosive dusts (such as coal handling or granaries) require special cable, connection components and control components that are approved for use in these areas. Installation of non-approved products can result in fires or explosions.**
- **Installation on plastic pipe requires special considerations in selections & installation. See the Nelson Heat Trace Design Guide for details in design and selection.**
- **To prevent creases it shall be assured that the minimum bending radius is 25 mm (1.0inch).**
- **All the self-regulating heating cables have minimum installation temperature of - 40°C (- 40°F).**

### **Scheduling**

The installation of the electric heat tracing requires coordination with the piping, insulation, electrical and instrument groups. Cable installation should begin only after the majority of mechanical construction is complete. Pressure testing of the pipe and installation of the instruments should be complete prior to the start of the heater cable installation.

### **Pre-Installation Check**

Walk the piping system and plan the routing of the heater cable. This action is used to verify completion of all instrumentation and mechanical work. All coatings (paint, etc.) and surfaces must be dry before attempting the heater cable installation.

### **Heater Handling**

- To avoid damage, use a reel holder to roll out the heater cable.
- Keep the cable strung loosely and close to the pipe being traced. This will avoid interference with supports and other equipment.
- Leave an extra 30-46cm (12-18") of heater cable at all power connections, tee splices and end seal connections to facilitate ease of working with the connections.
- **Additional heater cable is required on valves, pipe supports and other equipment.** See the installation detail section for exact lengths and method of installation.
- When handling the heater cable, avoid pulling it over or installing against sharp edges.
- Do not kink or crush the cable, including walking on it or driving over it with equipment.

## Heater Cable Location

The heater cable may be installed in either straight runs or spiraled around the pipe. Spiraling is generally used when a limited number of cable types are available. Where possible, the heating cable shall be applied flat to the heated object.

### Straight Tracing

When straight tracing is used, install the heater cable on the lower quadrant of the pipe. This helps prevent physical damage to the heater cable from falling objects and from being walked on.

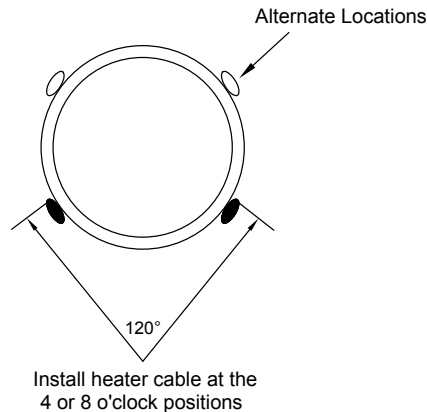

**Figure 2**

### Spiraling

Spiraling increases the length of heater cable installed per foot of pipe. Installed cable length = Pipe Length X Spiral Factor.

The following example and table will allow you to determine the correct pitch for each pipe size and spiral factor:

*Example: When using .43m (1.4ft) of heater cable on 102mm (4") IPS pipe, the Pitch (P) would be 356mm (14")*

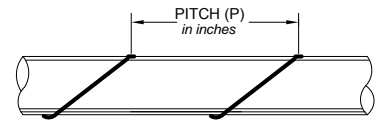

**Figure 3**

Table I  
Spiral Pitch Table (Inches)

Pipe Size (IPS)	SPIRAL FACTOR (feet of heater cable per foot of pipe)				
	1.1	1.2	1.3	1.4	1.5
1.0	NR	NR	NR	NR	NR
1.5	NR	NR	NR	NR	NR
2.0	17	NR	NR	NR	NR
2.5	20	14	NR	NR	NR
3.0	24	17	13	NR	NR
3.5	28	19	15	13	NR
4.0	31	21	17	14	NR
4.5	35	24	19	16	14
5.0	39	26	21	18	15
6.0	46	31	25	21	18
8.0	59	41	33	28	24

1 inch = 25mm

---

## Attachment

For normal installations, the heater cable may be attached with fiberglass tape. Plastic wire ties may also be used provided the plastic has a maximum temperature rating equal to or better than the system requirements. The cable should fit snugly against the pipe and be secured at one 305mm (12") intervals, as shown in Figure 4.

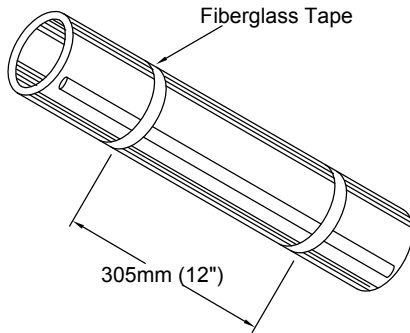

**Figure 4**

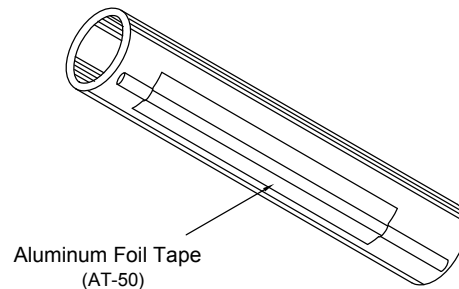

**Figure 5**

### Notes:

- 1) To prevent possible damage to the heater cable, do not fasten with metal straps, wire, vinyl electrical tape or duct tape.
- 2) Aluminum foil tape should only be used if specified by design. The tape is normally installed continuously along the entire length of the heater cable. The foil is most often used on plastic pipe to offset the insulating effect of the plastic. See the Nelson Heat Trace Design Guide for details. See Figure 5 above.

## Cutting the Heater Cable

Do not cut the cable until it is attached to the pipe. Confirm the allowances for terminations, connections and heat sinks (valves, support, etc.) before cutting the cable. Heater cable power output is not affected by cutting to length. Protect all heater cable ends from moisture and mechanical damage if exposed for long periods of time.

## Installation Details

Heater cables should be applied in a manner to facilitate the easy removal of valves and small in-line devices without the removal of excessive thermal insulation or having to cut the heater cable. The best way to accomplish this is to loop the cable. The amount of heater cable installed on each valve, hanger, etc. varies with the pipe size and type of device. Table II gives the correct amount of additional cable to be installed on each device.

---

## Installation Details (continued)

The following figures show installation details for various typical situations:

**Valve**  
Typical installation method  
*(may vary for different valve shapes)*

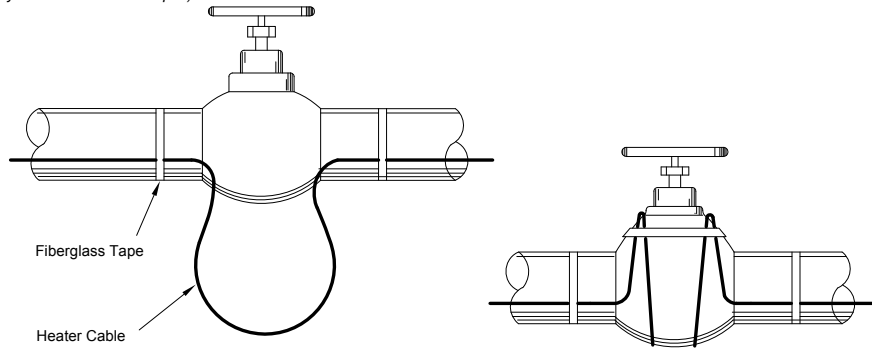

**Figure 6**

**Elbow**

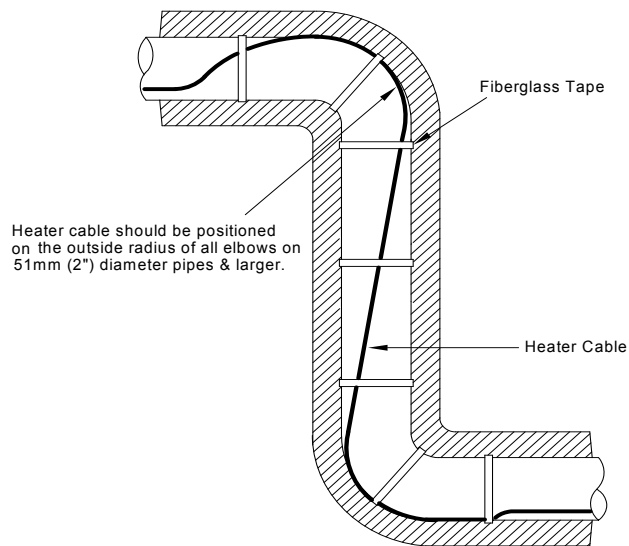

**Figure 7**

**Flange**

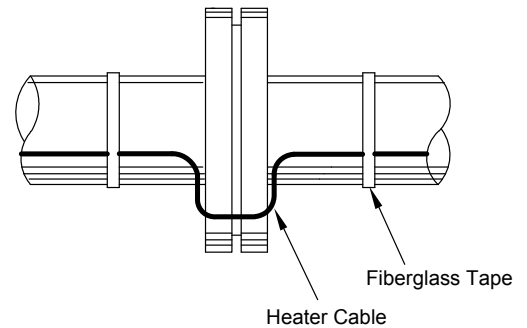

**Figure 8**

## Hanger Support

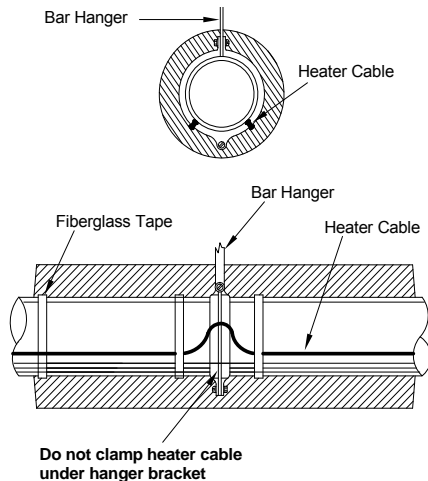

**Figure 9**

## Shoe Support

Side View

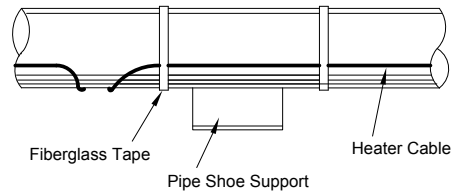

Bottom View

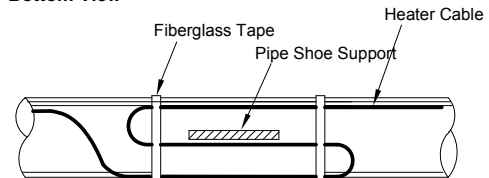

**Figure 10**

Table II  
Heat Loss Adder

Pipe Size	Pipe Fitting Type				
	Flange Pair	Vent & Drain	Pipe Support	Globe, Ball & Butterfly Valves	Gate Valve
.50	.30	1.0	1.0	1.0	1.0
.75	.30	1.0	1.5	1.0	1.5
1.00	.30	1.0	1.5	1.0	2.0
1.50	.30	1.0	2.0	1.5	2.5
2.00	.30	1.0	2.0	2.0	2.5
3.00	.30	1.0	2.0	2.5	3.0
4.00	.50	1.0	2.5	3.0	4.0
6.00	.80	1.0	2.5	3.5	5.0
8.00	.80	1.0	2.5	4.0	7.0
10.00	.80	1.0	3.0	4.5	8.0
12.00	.80	1.0	3.0	5.0	9.0
14.00	1.0	1.0	3.0	5.5	10.0
16.00	1.0	1.0	3.5	6.0	11.0
18.00	1.0	1.0	3.5	7.0	12.0
20.00	1.0	1.0	3.5	7.5	13.0
24.00	1.0	1.0	4.0	8.0	15.0

1 foot = 30.5 cm

**Notes:**

- 1) Nominal pipe length is given in feet. Adders are for various in-line pipe fittings to compensate for greater areas of heat loss.
- 2) Values above are based on area average of various fittings available with the assumption that fitting insulation will be equivalent to pipe insulation. The nominal length of tracer to be applied to a particular fitting would be the value shown in this chart plus the flange-to-flange length of the fitting.
- 3) For a flanged valve, choose Valve Type and then add one Flange Pair for total adder length.

---

## SYSTEM COMPONENTS

Only Nelson Heat Trace approved termination, connection and splice kits should be used in accordance with manufacturer's installation instructions. Failure to do so will void warranties and agency approvals. For the connection of the heating cable to power, certified enclosures must be used that are suitable for the application and are correctly installed. When connecting to Ex e or other certified terminals using associated accessories, the required creepage distances and clearances shall be observed. Other terminations and connections, not mentioned in this document, that are to be installed as an integral part of the heating cable system, shall be certified according to the requirements of the applicable standards for their types of protection. Installation instructions in each component kit should be followed regarding heater cable preparation and assembly. Make end terminations and splice connections before making the power connections. It is recommended that all heater cables be tagged as they are installed with a discrete circuit number. Proper labeling will facilitate identification, component requirements and electrical wiring during later phases of the installation. Power, splice and tee connection kits utilize adapters for installation on equipment other than piping systems such as instrument tubing and tanks. Installation instructions for proper mounting are included in each kit.

### Accessories

Certification details can be found in the installation instructions of individual accessories, if applicable.

Type	Description	Applicable for
PLT Series	Connection System, non-metallic	LT, QLT, HLT
ALT Series	Connection System, metallic	LT, QLT, HLT
HASK Series	Connection System, Division 1 only	D1-LT, D1-HLT
Z1-PLT Series	Connection System, Zone 1, non-metallic	LT, QLT, HLT
Z1-ALT Series	Connection System, Zone 1, metallic	LT, QLT, HLT
AX Series	Connection System, NEC Wiring Methods	LT, QLT, HLT
EX Series	Connection System, IEC Wiring Methods	LT, QLT, HLT
HEC100	Connection System, end termination	LT, QLT, HLT
HEL100	Connection System, lighted end termination	LT, QLT, HLT
HPC, HSC, HTC	Connection System, termination components	LT, QLT, HLT
LT-ME, LT-MP	Cable Seal Kit	LT, QLT, HLT
LT-SE, LT-SP	Cable Seal Kit, shrink tubing	LT
LT-HSE, LT-HSP	Cable Seal Kit, shrink tubing	HLT
LT-SS, HSK-85	Splice Connections, shrink tubing	LT
LT-HSS	Splice Connections, shrink tubing	HLT
HPS, HES	Cable Seal Kit	LT, QLT, HLT
GH-M25	Heater Cable Gland	LT, QLT, HLT
HCSK	Heater Cable Sealing Kit	LT, QLT, HLT
GHK-M25	Termination Kit	LT, QLT, HLT

Refer to Figure 11 for common examples of heating cable and accessories installation for a standard piping application.

**⚠ WARNING:**

Connecting bus wires together will create an electrical short.

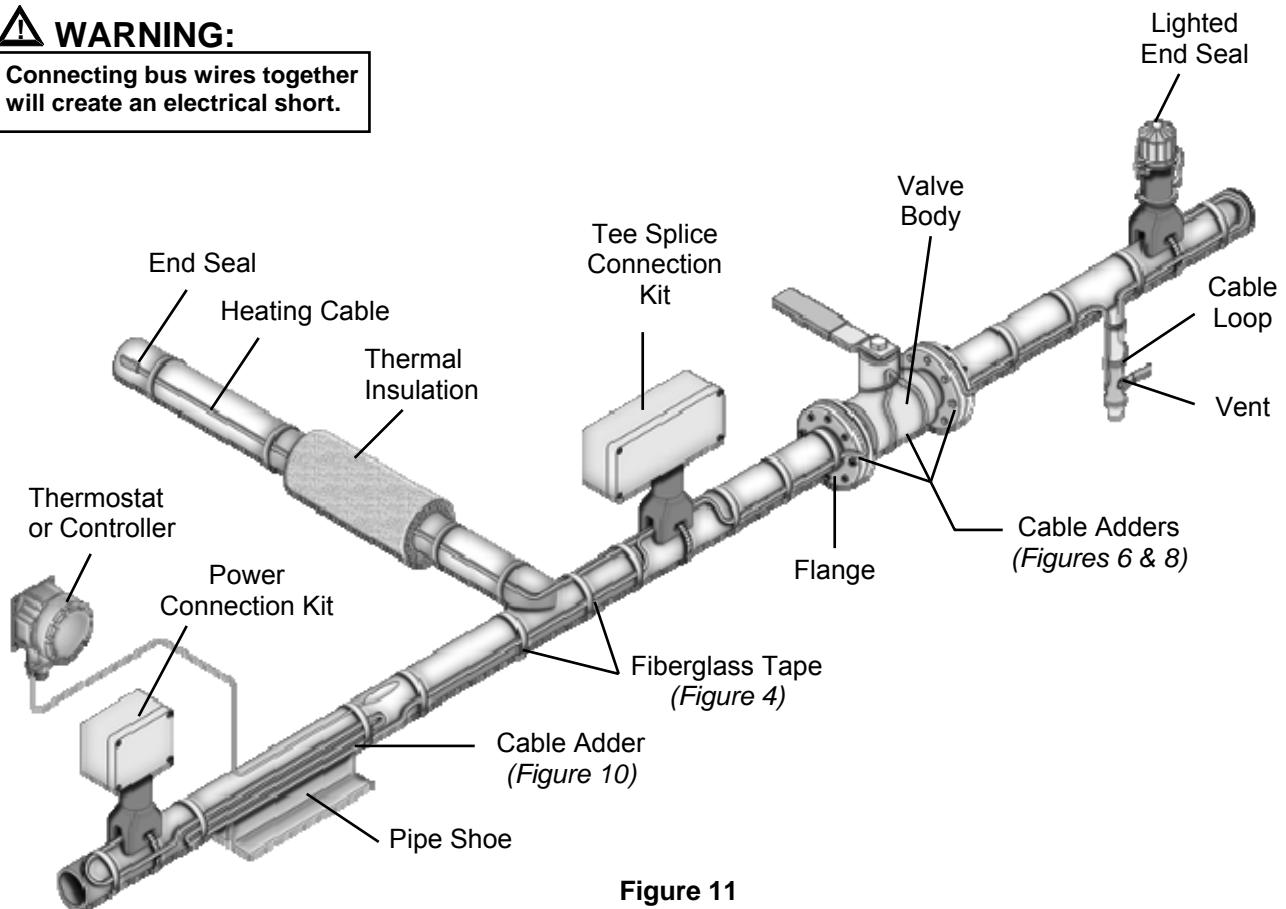

**Figure 11**

## THERMAL INSULATION

### **Pre-Installation Checks**

Inspect the heater cable and components for correct installation and possible damage. In particular, verify that:

- The correct additional amount of heater cable has been installed at each valve, flange, pipe support, etc. and that it is free from nicks, tears or gouging. Additional cable beyond the specified amount at a heat sink is not a problem due to the self-regulation effect of the heater cable.
- Connections, splices and end seals are correctly installed, including cable seals in power connection enclosures.

### **Installation**

Check the thermal insulation type and thickness against the design criteria. Changes in insulation type and/or thickness may require a different heater cable. Verify that all pipe work, including wall penetrations, fittings, etc. has been completely insulated.

Check the system to verify that:

- Insulation is not wet from rainfall or leakage prior to the application of waterproofing.
- Lap joints on vertical piping are properly installed - higher piece lapped over the top of lower piece.
- Band seals are used at lap joints to prevent the ingress of water.
- All penetrations of lagging (valve stems, hanger rods, etc.) are properly water proofed.
- Irregular shaped items (i.e. pumps, etc.) are properly waterproofed.

---

To minimize potential damage to the heater cable, install the insulation as soon as possible. It is recommended that another insulation resistance (megger) test be done after the insulation has been installed to verify that the heater cable was not damaged during the insulation installation.

### **Marking**

Install "Electric Trace" signs on alternate sides of the piping at regular intervals as a warning to maintenance personnel. Permanently mark the outside of the insulation lagging with the location of heater cable components. This will facilitate maintenance in the event of a problem.

## THERMOSTATS & SENSORS

Temperature sensitive applications will require the use of temperature control. Selection of the proper thermostat or controller must consider voltage and amperage ratings of the device as well as the suitability of housing for the environment (explosion proof, rain tight, corrosion resistance, etc.). The enclosure housing should be mounted as close as possible to the power connection kit. It may be attached to the power connection kit provided code requirements are met with regard to connections seals, etc. To sense the coolest air temperature, ambient (air sensing) thermostats should be mounted in the shade when possible. When using pipe-sensing thermostats, the bulb (sensor) should be mounted on the opposite side of the pipe from the heater, or as far away as is practical. This will allow the thermostat to sense the actual pipe temperature and not be influenced by the heater temperature. Mount the bulb at least three (3) feet from the closest heat sink if possible.

Moisture inside the enclosure will cause both corrosion and electrical shorting problems. The potential for this type of problem can be greatly reduced by:

- Proper sealing of all enclosures openings.
- Keeping enclosure cover closed and secured as much as possible during installation sequence.
- Proper closing and sealing of the cover to prevent leaking into the housing.
- Use of a moisture proofing/electrical spray (aerosol) sealant on thermostat and electrical connections (including all metal parts) at completion of installation.
- Connection and use of space heater if thermostat is so equipped. **Do not de-energize space heater during summer months.**

## ELECTRICAL REQUIREMENTS

### **Voltage Rating**

Verify that the heater cable voltage rating is suitable for the service being used. Cables with 240 volt ratings may be used with voltages from 200 to 277 volts, with an accompanying change in power output. See Nelson Heat Trace Design Guide for power correction factor. Nominal voltage and wattage ratings are printed on the heater cable.

### **Electrical Loading**

Size the branch breakers or over-current protective devices according to Nelson Heat Trace Specification and Application Literature.

### **Protection Requirements for Branch Circuits**

The National Electrical Code requires ground fault protection of equipment for electric heat tracing and heating panels. This requirement shall not apply in industrial establishments where there is alarm indication of ground faults and the following conditions apply:

- (1) Conditions of maintenance and supervision ensure that only qualified persons service the installed systems.
- (2) Continued circuit operation is necessary for safe operation of equipment or processes.

---

The Standards EN 60079-30-1:2007 and IEC 60079-30-1:2007 have the following minimum requirements for heat trace systems for use in explosive gas atmospheres:

All line conductors must have the ability to be isolated from the associated electrical supply.

Over-current protection must be provided for each branch circuit.

Protection against earth faults is required for all circuits. (See IEC 60364-5-55 for definitions).

For TT and TN systems:

The trace heater branch circuit protection shall be capable of interrupting high-impedance earth faults as well as short circuit faults. This shall be accomplished by an earth-fault protective device or controller with earth-fault interruption capability for use in conjunction with suitable circuit protection. The preferred trip level for adjustable devices is 30 mA above any inherent capacitive leakage characteristic of the heater as specified by the trace heater supplier. Where conditions of maintenance and supervision ensure that only qualified persons will service the installed systems, and continued circuit operation is necessary for the safe operation of equipment or processes, earth-fault detection without interruption is acceptable if alarmed in a manner to ensure acknowledged response.

For IT systems:

An electrical insulation monitoring device shall be installed to disconnect the supply whenever the electrical resistance is not greater than  $50 \Omega / V$  of rated voltage.

## **Waterproofing**

Moisture penetration of the electrical system is the single largest source of problems in a heater cable installation. Particular care must be given to the proper sealing of all electrical connections and splices. Heater cable sealing kits will provide a proper seal for the heater cable itself when used per kit instructions. All other electrical connections (heater to power wiring, thermostat connections, panel and breaker connections, etc.) should be sealed or moisture proofed in some fashion. Either mastic shrink tube or an aerosol electrical insulative sealant should be used on all connections to reduce any moisture penetration. The sealant will also reduce the potential for corrosion on exposed metal parts.

## **Testing**

Electrical tests are required at specific points in the installation of the heater cable. Periodical testing is designed to prevent the expenditure of wasted labor in the event of damage to the product. Installation costs of the cable and thermal insulation are much greater than the cost of the heater cable itself. Quick identification of any heater cable damage is the most economic approach to an installation. An insulation resistance test should be performed at the following points during the installation process:

- Upon RECEIPT of the heater cable
  - BEFORE thermal insulation installation
  - Immediately AFTER thermal insulation installation
- Note: ATEX certified installations require megger at this point*
- As part of a PERIODIC MAINTENANCE program

## Procedure

The insulation resistance test is used to check for damage to electrical jackets. Connections for the megger are shown in *Figures 12 & 13*.

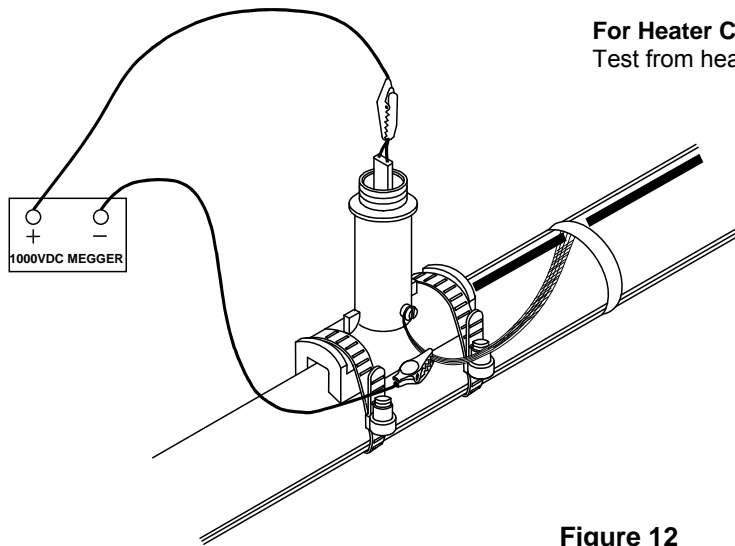

**⚠ WARNING:**  
Do not connect bus wires together in the end cap as this will create an electrical short.

Figure 12

*Note: Test should use a minimum 1000 VDC megger. Do not use a megger with an excess of 2500 VDC. Minimum acceptable readings should be 20 megohms per circuit, regardless of length.*

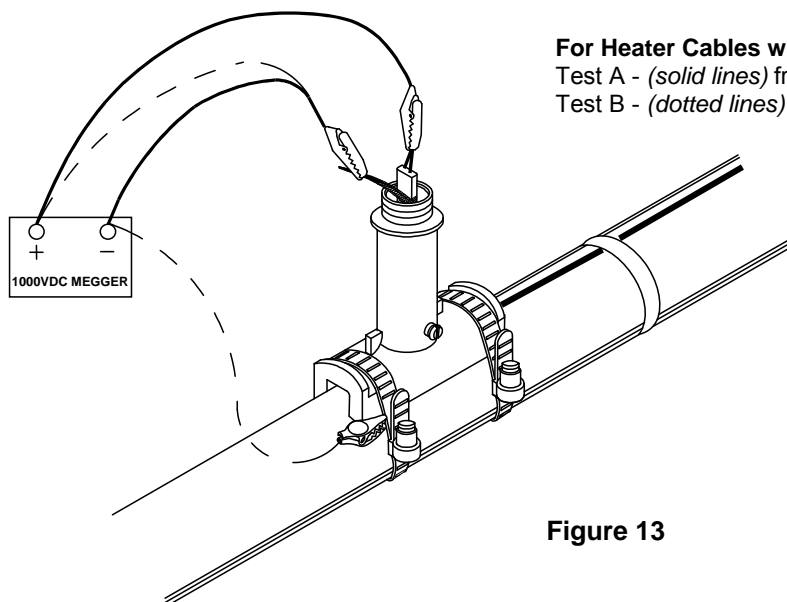

**⚠ WARNING:**  
Do not connect bus wires together in the end cap as this will create an electrical short.

Figure 13

A record should be kept of the readings taken from the time the cable is first installed on the pipe. A history of the insulation resistance reading can be helpful in spotting moisture ingress into the electrical system by seeing a gradual decline in the insulation resistance or physical damage to the heater cable by seeing a sharp decline in the insulation resistance. A sample record for this is shown in *Figure 14*.

# NELSON HEAT TRACE

Circuit Number
Heater Type
Circuit Length

## Periodic Inspection Record

### Freeze Protection Circuits -

Perform these checks as season requiring use approaches.

### Temperature Maintenance Circuits -

Perform these checks at least twice per year.

Maintenance Checks for _____		Month _____	Year _____			
Visual inspection inside connection box corrosion, moisture, etc.	Initial					
	Date					
Damage or cracks (leaks) in insulation seals at valves, hangers, pumps, etc.	Initial					
	Date					
Heater cable properly connected and grounded. Heater cable and connections insulated from connection box.	Initial					
	Date					
Thermostat checked for moisture, corrosion, set point, switch operation, and capillary damage	Set Point					
	Initial					
	Date					
Megger tests performed at power connection with both bus wires disconnected from power wiring.	Reading					
	Initial					
	Date					
Circuit voltage at power connection.	Reading					
Circuit amperage after 5 minutes	Reading					
Pipe temperature at time amps were measured.	Reading					
Watts/Ft.						
Volts x Amps = w/ft. feet	Initial					
	Date					
All connections, boxes, and thermostats have been resealed.	Initial					
	Date					
End seals, covered splices and tees marked On insulation cladding.	Initial					
	Date					

Remarks & Comments						

Periodic Inspection Record Form

**Figure 14**  
**Periodic Inspection Record Form**

The Periodic Inspection record Form may be used in one of two ways:

- 1) **One Sheet per Circuit.** - The results of periodic tests of a single circuit are posted in vertical columns, beginning on the left and working toward the right. This allows easy comparison of test values for up to seven test sequences on an individual circuit.
- 2) **One Circuit per Column.** - Test data for a single test sequence can be recorded on a single sheet.

# Heat Trace Installation Record



1. Circuit No. \_\_\_\_\_

2. Receiving Documentation

Date \_\_\_\_\_

Item

**DESIGN**

**ACTUAL**

A. Cable Type

\_\_\_\_\_

\_\_\_\_\_

B. Cable Length

\_\_\_\_\_

\_\_\_\_\_

3. Receiving Testing

Date \_\_\_\_\_

A. Check for physical damage

Test Value/Remarks \_\_\_\_\_

B. Continuity Check

Check for continuity between buss wires

Test Value/Remarks \_\_\_\_\_

C. 500VDC min., 2500VDC recommended, megger check between leads and cable sheath, 20 megohms minimum value

Test Value/Remarks \_\_\_\_\_

D. Lot No.

No. \_\_\_\_\_

4. Post Installation Testing

Date \_\_\_\_\_

A. Continuity Check

Check for continuity between cold leads

Test Value/Remarks \_\_\_\_\_

B. 500VDC min., 2500VDC recommended, megger check between leads and cable sheath, 20 megohms minimum value

Test Value/Remarks \_\_\_\_\_

C. Visually Check Cable Installation Prior to Release for Thermal Insulation

Test Value/Remarks \_\_\_\_\_

5. Final Testing and Commissioning

Date \_\_\_\_\_

A. Circuit approved for testing by client

Approved \_\_\_\_\_

B. 500VDC min., 2500 VDC recommended, megger check between leads and cable sheath, 20 megohms minimum value

Test Value/Remarks \_\_\_\_\_

C. Energized Testing

(all test data to be within 10% of design data)

**DESIGN**

**ACTUAL**

1. Circuit Voltage

\_\_\_\_\_

\_\_\_\_\_

2. Initial Current

\_\_\_\_\_

\_\_\_\_\_

3. Current after 15 minutes of operation

\_\_\_\_\_

\_\_\_\_\_

4. Current after 30 minutes of operation

\_\_\_\_\_

\_\_\_\_\_

5. Pipe temperature

\_\_\_\_\_

\_\_\_\_\_

6. Circuit Acceptance

\_\_\_\_\_

\_\_\_\_\_

*This circuit has been tested and documented in accordance with the above itemized data. This circuit by:*

Contractor \_\_\_\_\_

Date \_\_\_\_\_

Client \_\_\_\_\_

Date \_\_\_\_\_

The **Heat Trace Installation Record** can be used to monitor the initial installation and check out process. This form can be used in conjunction with the **Periodic Inspection Record** shown in *Figure 14*.

**Figure 15**

---

## START-UP

### **Heat-up Time**

Heat-up capacity (the ability to heat the pipe and its contents rapidly) is not normally designed into the system. Cold start-ups should allow adequate time for the pipe to come up to temperature.

### **Diversity Factor**

If the electrical supply capability is limited, then a diversity factor may be used in a cold start situation. This is accomplished by staggering the initial turn on of the heater cable circuits to allow the inrush currents to occur in a sequential fashion rather than all at once.

## OPERATION & MAINTENANCE

### **System Design, Installation & Documentation**

The heater cable system must be properly designed, installed and documented. This documentation should include line lists and location identification documentation. As-built installation drawings provided the optimum maintenance tool. Test records should also be considered as part of the system documentation requirements. See Figure 15.

### **Preventive Maintenance**

A preventive maintenance program is needed which will encompass both visual and electrical checks of the system. These should be done not only before initial operation of the system, but also on a scheduled basis. The checks should also be done after any maintenance has been performed.

### **Visual Inspections**

- Thermal insulation - check weatherproofing for damage, missing seals, cracks or gaps in caulking and mastic coatings, damaged or missing lagging. When damage does exist, the insulation will need to be repaired or replaced, and then resealed. **Wet insulation has poor insulating properties and must be kept dry at all times.** If insulation has been damaged, check the heater cable for damage and replace any damaged sections.
- Inspect junction boxes, connection boxes and thermostats for corrosion, moisture or foreign matter.
- Tightness of electrical connections, proper electrical insulation of heater cable wires, adequacy of moisture seal on electrical connections and that a minimum of one (1) inch of electrically insulated heater extends above the grounding connection. No strands of the ground braid should extend above this connection.
- Check all thermostats or sensor capillary leads to verify they are tied back and shielded from physical damage.
- Verify all enclosure, connection box, etc. covers are properly closed and that the thermostat is switching off and on by measuring current flow in the circuit when the unit switches on. Reset the knob to the proper temperature after completion of the test.

### **Frequency**

Inspections should be made prior to the start of the season on freeze protection systems. Process maintenance systems should be checked on a frequent basis, at least twice a year.

### **Personnel Training**

Qualified maintenance personnel must be used to maintain the system. It is recommended that periodic training programs be utilized to assist in keeping maintenance personnel up to date on equipment and procedures.

---

### ***Maintenance***

The heater cables will not require any maintenance. Mechanical temperature controls should be sprayed with a moisture repellent/corrosion inhibitor once a year on all metal parts.

### ***Piping Repairs***

Disconnect the electrical connection from the heater cable and protect it from mechanical or thermal damage during the repair. Check the heater cable installation after the repairs per established procedures. Replace and water seal the thermal insulation system.

### **DAMAGED PRODUCTS**

Do not attempt to repair a damaged heater cable. Fault currents will often destroy the bus wire / core material interface between the damaged portion and the voltage supply end of the circuit.

Replace the damaged heater cable immediately. Moisture migration into the good section of the heater cable may cause electrical shorting in that cable after repair of the damaged section.

Any product exposed to fire or flame should be removed from service immediately and replaced. Further fire damage could result if energized.

## TROUBLESHOOTING

SYMPTOMS	PROBABLE CAUSE	CORRECTION
<b>A. Circuit Breaker Trips (Standard)</b>	<ol style="list-style-type: none"> <li>1. Circuit breaker undersized</li> <li>2. Circuit length is longer than designed</li> <li>3. Start-up temperature is lower than designed</li> <li>4. Defective circuit breaker</li> <li>5. Connections or splices may be shorting out</li> <li>6. Physical damage to the heater cable may be causing a short</li> <li>7. Wires connected at end seal</li> </ol>	<ol style="list-style-type: none"> <li>1, 2, 3. Re-establish the current loads and resize the breakers*</li> <li>4. Replace circuit breaker</li> <li>5, 6. Locate and repair incorrect or damaged connections, splices, or sections of heater cable. ** Megger per installation instructions</li> <li>7. Disconnect wires and perform a current check for possible other damage</li> </ol>
<b>B. Circuit Breaker Trips (Ground Leakage Type)</b>	<ol style="list-style-type: none"> <li>1. All of section A</li> <li>2. Excessive moisture in connection boxes or splices</li> <li>3. Nick or cut in heater or power supply wire with moisture present</li> </ol>	<ol style="list-style-type: none"> <li>1. All of section A</li> <li>2. Dry out and re-seal connections and splices. Megger per Installation Instructions (20 megohms min.) Work on connections outside the thermal insulation first, going to the below insulation connections and seals after the others have been eliminated</li> <li>3. Locate and repair or replace damaged heater cable or power wire **</li> </ol>

\*Check to see if existing power wire sizing is compatible with larger sized breakers.

\*\*To locate shorting problems, follow these steps:

- 1) Visually inspect the power connections and splices that are outside of the thermal insulation for proper installation.
- 2) Check around the valves, pumps, and any area where there may have been maintenance work done for visual indications of damage.
- 3) Look for crushed or damaged insulation lagging along the pipe.
- 4) Inspect heater cable splices, if any, that are located under the thermal insulation.
- 5) If you have not located the problem by now, you will have to isolate one section of the heater cable at a time until you determine the general area of damage. First, isolate sections by disconnecting any tees or splices then remove insulation from that area until the specific damage is found. For long runs of cable, it may be necessary to cut the cable in half to isolate the shorted section.

SYMPTOMS	PROBABLE CAUSE	CORRECTION
<p><b>C. Power output is zero or lower than rated ***</b></p>	<ol style="list-style-type: none"> <li>1. Low or no input voltage</li> <li>2. Circuit is shorter than designed               <ol style="list-style-type: none"> <li>a. Splices or tees may not have been connected</li> <li>b. Heater cable may have been severed</li> </ol> </li> <li>3. Improper crimping causing a high resistance connection</li> <li>4. Control thermostat is wired in the opened position</li> <li>5. Pipe is at an elevated temperature</li> <li>6. Heater cable has been exposed to excessive moisture</li> <li>7. Heater cable has been exposed to excessive temperatures</li> </ol>	<ol style="list-style-type: none"> <li>1. Repair electrical supply lines and equipment</li> <li>2. Check routing and length of heater cable and recalculate power requirements               <ol style="list-style-type: none"> <li>a. Connect and recheck the power</li> <li>b. Locate and repair the damaged heater cable. Recheck the power</li> </ol> </li> <li>3. Re-crimp using correct procedure</li> <li>4. Rewire in the normally closed position</li> <li>5. Check pipe temperature and recalculate the power output ***</li> <li>6, 7. Replace the heater cable</li> </ol>
<p><b>D. Power output appears correct but pipe temperatures are below design values</b></p>	<ol style="list-style-type: none"> <li>1. Insulation is wet</li> <li>2. Insufficient heater cable used on valves, supports, and other heat sinks</li> <li>3. Thermostat was set incorrectly</li> <li>4. Thermal design inconsistencies</li> </ol>	<ol style="list-style-type: none"> <li>1. Remove and replace with dry insulation and insure proper weatherproofing</li> <li>2. Splice in additional heater cable but do not go over maximum circuit length</li> <li>3. Reset the thermostat</li> <li>4. Check with the local or factory representatives for design conditions. Modify as recommended</li> </ol>

\*\*\* The power output on self-regulating heater cable is temperature sensitive and requires a special procedure to determine its value.

- 1) Check the pipe temperature under the thermal insulation.
- 2) Allow heater cable to stabilize for 10 minutes and then measure the current.
- 3) Calculate the power (watts / ft.) of the heater cable by multiplying the current by the input voltage and dividing by the actual circuit length,  $I \times V / Ft. = Watts / Ft.$
- 4) Compare this measured value to the power output curves for the heater cable at the measured pipe temperature. If the heater cable's actual output is substantially below the theoretical output, the cable may have been damaged by excessive temperature exposure or fault currents and the cable must be replaced. This is not a highly accurate method of analysis; judgment should be used when comparing theoretical and actual values.

